

HEAVY DUTY BLAST DAMPERS 14 PSI RANGE (96.5kpa)

Information & Spec Sheet

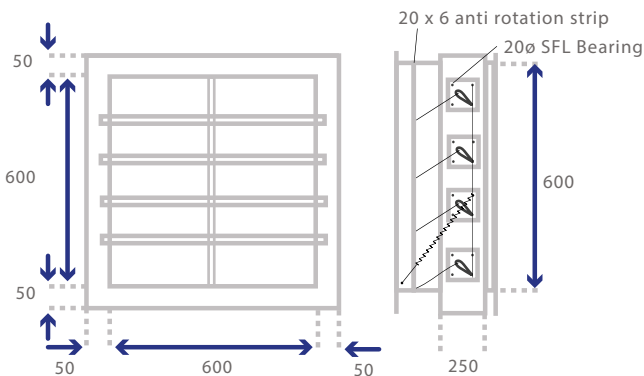

DESIGN

A Blast Damper is used to Protect Occupants and Equipment of a Structure Against Overpressures Resultant of an Explosion. The Blast Dampers normally protect Air Inlets and Exhaust Penetrations in Ventilation Ducts. Current Designed is Based on Debris Free Pressure Blast. Used on Switchgears and Petrochemical Sites for example.

Blast Dampers Usually Employ some Type of Blade held open with tension from a spring.



All Engineered Air Treatment Damper designs have been tried and tested for over 35 years.

The damper blades close automatically when pressure overcomes the Resistance Offered by the Spring. Various Models Differ in the amount of Blast Protection (e.g. 1bar/14.psi or lower amounts of protection) and whether they stay closed after the blast or remain functional.

FEATURES

- Heavy Duty Design
- Independently Tested By 3rd Party
- Various Materials Available
- Designed To Either Spring Open To Release Pressure Or Close To Withstand Blast
- Drilled At 150 CTRS For Sounds Installation Support
- Mechanism Covered For Safety Reason.
-

All materials used are class 'A' Fully traceable as part of ISO 9001



STANDARD LAYOUT

MATERIALS	Pre-Galvanised M.S. to BS EN 10346 2015 DX51D
CASING	3mm Pre-Galvanised M.S. Fully Welded
BLADES	2mm Interlinked to rise and fall in unison these are held in default position by adjustable spring- this spring is adjusted by final installer not by E.A.T. Ltd
SPINDLES	20mm dia Solid Stainless steel 304
HARDWARE	BZP
BUSHES	20mm SFL minimum
MESH	1/2" x16g Mesh Fingerguard ideal for keeping fingers and pests out
FINISH	Self colour all welds cleaned and dressed

OPTIONS FOR MATERIALS

MATERIALS	304 or 316 Stainless Steel
CASING	5mm
BLADES	3mm
SPINDLES	304 or 316 Stainless Steel
HARDWARE	Stainless Steel
MESH	Available

ADDITIONAL DAMPER INFORMATION

Engineered Air Treatment Ltd. Pride themselves on solving Damper issues and due to the many options available we would recommend contacting our sales team who would also assist where possible.



We have experience of supplying dampers from -30°C to +80°C



Approx 40Kg's per m². We can supply lifting eyes if required.



Please see graph over-leaf



Minimum 150mm, maximum 2000mm Module size, For bigger sizes speak to sales staff.

OPTIONAL EXTRAS

- Microswitches to Signal Open or Closed
- ATEX Rating
- Visual Indication

LAYOUT

Maximum Module Size 600 X 1000 - Sizes above this will Consist of Multiply Modules.

INSTALLATION

Damper comes with Flanges Drilled, Holes at 150 CTRS and 12mm Diametre. We Recommend 8mm Fixing Minimum.

PRESSURE DROP

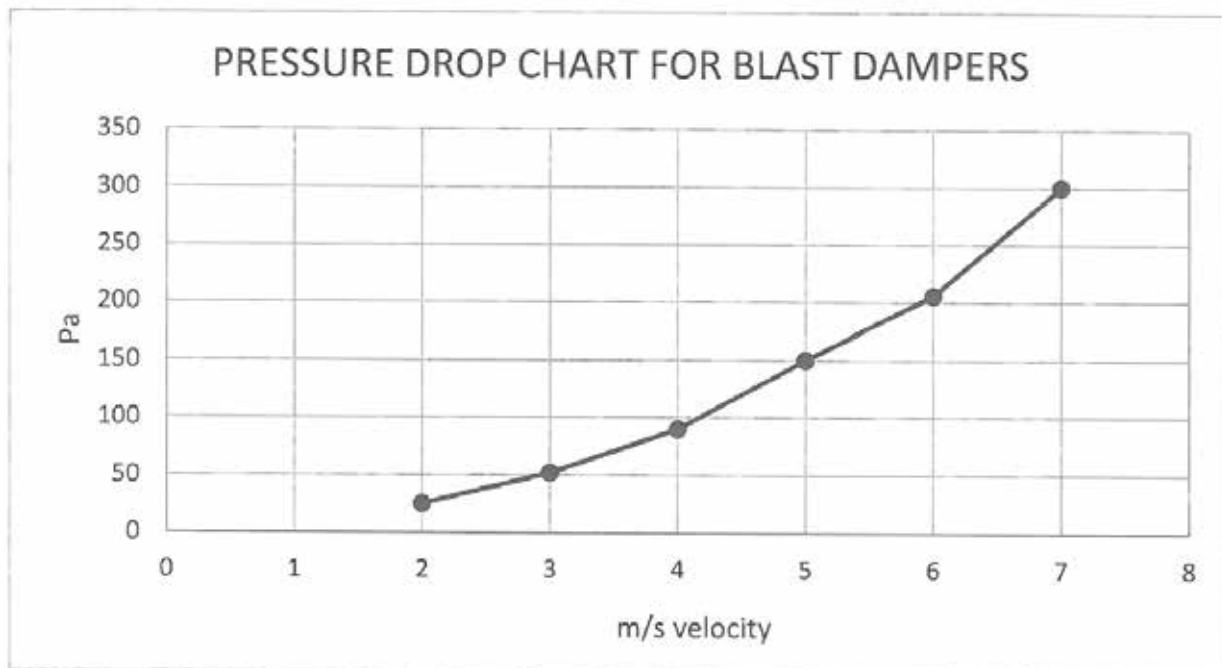

STANDARD MODULE LAYOUT

This is Based on 500mmsq. Damper Module, For Example a 1000mm wide x 500mm High would be a manufacture from 2 modules.

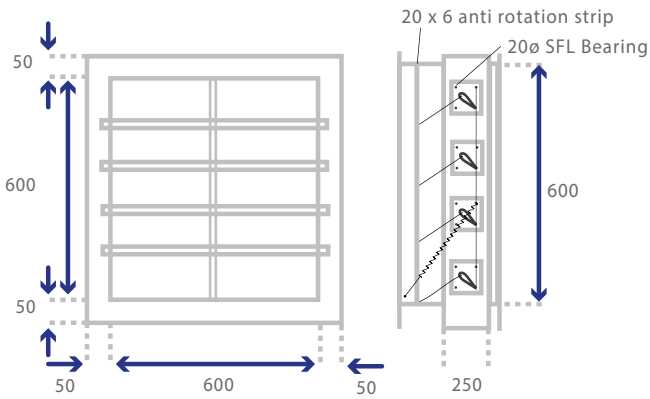

Multiple Layout and Sizing Available.

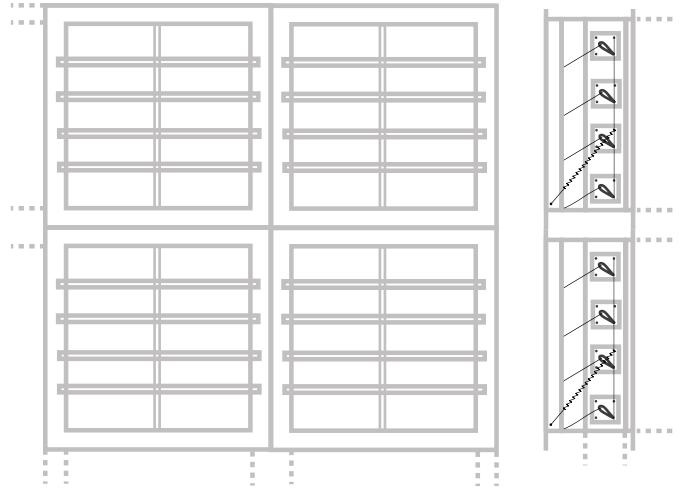

Please Contact Our Sales Staff For Further Information

TESTS

They have been tested by BSRIA using standards BSEN1751:1999 class 2 (see test report 53356-1)

:

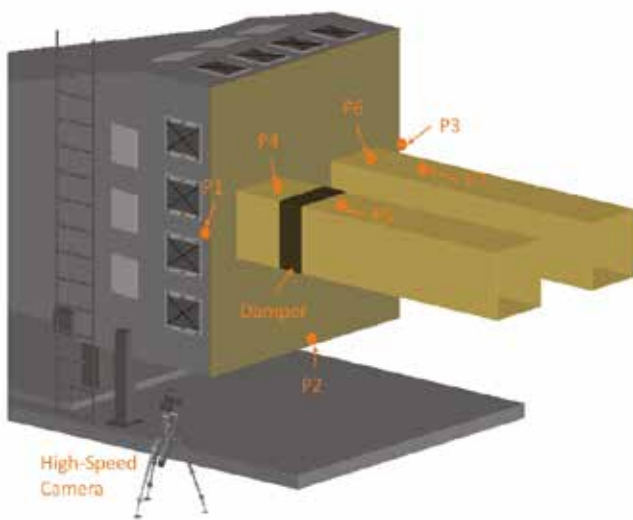

Independently tested in the USA.

Peak Test Loaded: 10 PSI

Impulse: 560 PSI-MS

Duration: 112 Milliseconds

DAMPER FLANGES TO COME WITH HOLES @ 150 CTRS AND 12MM DIA
RECOMMENDED FIXING IS A 8MM FIXING.

Video of Test Available on Request.



Engineered Air Treatment are proud of our quality record which allows us to have complete confidence in the products we offer. We adhere to our ISO9001 accreditation and install these values into our valuable employees. This confidence allows us to offer a 2 year warranty with all our products.

We also have complete traceability and files over 20 years old to look back on. We are a can do company.

CE Marking for Standard Gas Retention Dampers

The CE marking shall be the only marking which attests the conformity of the product with the applicable requirements of the relevant Community harmonisation legislation providing for its affixing”

There is also currently no relevant Community Harmonisation Legislation for a standard damper to adhere to and so CE marking to an official European standard is not possible.

CE Marking is required if dampers are Classed as fire rated safety products or according the building regulation 2016 a supporting the structure of the building, that is unless it comes into the Bespoke construction Section of the legislation and then due care and diligence needs to be illustrated.

This is our own interpretation of the current legislation and would react accordingly if required by law.

Engineered Air Treatment Ltd are a ISO9001: 2015 certified company, and can offer full material certification and traceability. We can also issue Certificate of Conformity, stating that we have supplied as ordered. We also supply EC Declaration of Incorporation with our products.