

FIRE DAMPERS

(CURTAIN TYPE)

Information & Spec Sheet

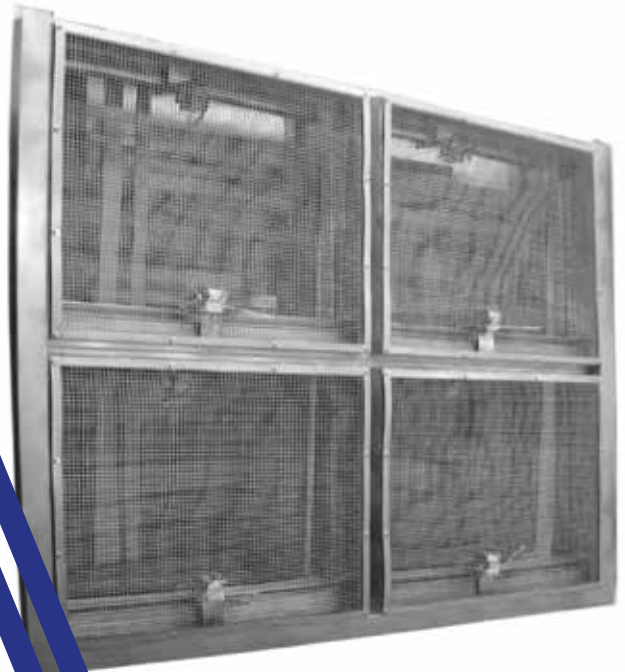

DESIGN

The purpose of a Fire damper is to prevent the progression of Fire through the system. A combination fire damper and Motorised Damper can also allow for a fire rating air control. The fire Damper must maintain its physical integrity in the most demanding conditions of temperature, and throughout this period it must maintain integrity. Careful consideration and evaluation should therefore be made when choosing your fire/smoke damper.

Fire dampers do not specifically address leakage rates at ambient or fire situation and where smoke is possible, we strongly recommend a Motorised Smoke/Fire Damper. The blades are supplied in either stainless steel or galvanised, with opposed blade operation.



All Engineered Air Treatment Damper designs have been tried and tested for over 35 years.

FEATURES

- Pre-slotted Flange Arrangements
- Economical variety of the Motorised Smoke/- Fire Damper
- Dampers in Dry environment have very little Maintenance requirements
- 2 Year warranty from date of despatch
- Excellent Customer Service from Engineers that have manufactured the dampers they sell. Our Sales Staff have over 30 years' experience, we could if they wanted to build your damper.

All materials used are class 'A' Fully traceable as part of ISO 9001



OPERATION

In the event of a fire, the fusible link will melt. When this melts the blades are free to close. The Blades are spring assisted and will slide down the casing closing the open face. The Blades will stay closed until reset by hand a new fusible link would be required at this stage.

STANDARD LAYOUT

MATERIALS	Pre-Galvanised M.S. to BS EN 10346 2015 DX51D
CASING	1.7mm Fully Welded and Cleaned for Smoother finish Coated in silver enamel
BLADES	0.8mm 'Z' Type Double Skinned, parallel opening standard. Pull ring each side for re-set
FLANGES	2mm and Pre-Slotted 150ctrs -TO THE AF FRAME DETAIL, SEE FIXING METHODS.
MESH	1/2" x16g Mesh Fingerguard ideal for keeping fingers and pests out
FUSIBLE LINK	95°C links as standard (72 and 120 available)
MATERIALS	Optional Materials 304 and 316 stainless steel
GASKET	Thermastrip gasket supplies loose for metal to metal applications.

RELIABILITY

The Fire Dampers have undergone a series of reliability tests. All models have been successfully cycled 250 times with out failure. The stainless steel negator springs have been cycled 5000 times without failure. The dampers have also been evaluated after dust loading. The test is designed to simulate the build up of dust and airborne particles which occur in duct systems over long periods of time. These particles may inhibit the positive closure of the fire dampers. Sample dampers were exposed to a circulating grain dust air mixture. The particles are allowed to accumulate on the various parts of the dampers after which the damper were removed from the chamber and successfully tested fire closing and latching

ADDITIONAL DAMPER INFORMATION

Engineered Air Treatment Ltd. Pride themselves on solving Damper issues and due to the many options available we would recommend contacting our sales team who would also assist where possible.



We have experience of supplying dampers from -40°C to +100°C



We would assume 30kg's a square meter for estimations



See performance Data graph



See Base Dimensions for Fire Dampers

TESTS

The Slotted Flange System is Tested by BRE for an Ad Hoc 2Hr fire test to BS476: Part 22: 1987 for 120 minutes.

The individual Test Cells are supplied by BSB-Damper and have been tested with alternative fixing methods. The results show the system can achieve the following:

- Complies to BS EN15650
- E classified fire dampers with reduced smoke leakage characteristics (BS EN 13501-3)
- Tested installation methods in differing supporting constructions (BS EN 1366-2)
- Tested and assessed installation methods in differing supporting constructions (BS 476-20/22) CE
- Marked complying with the requirements of BS EN 15650 for approved installation methods
- Slotted Flanges as standard on multiple units and adhere to the BRE test report P105847-1000 issue 1- Adhoc fire resistance test on FS-DBD Double Bank Dampers in steel panel walls, This report confirms construction for the FS-DBD damper and is adhered to for the fire damper-curtain type as well. 6MM steels required between modules for multiple sections. see example.

Adheres to DW144 not exceeding 1000Pa

OPTIONAL EXTRAS

Mechanical Visual Indicator

To provide local indication of the blade status.

When the indicator appears in the bulb, this shows that the blades are closed.

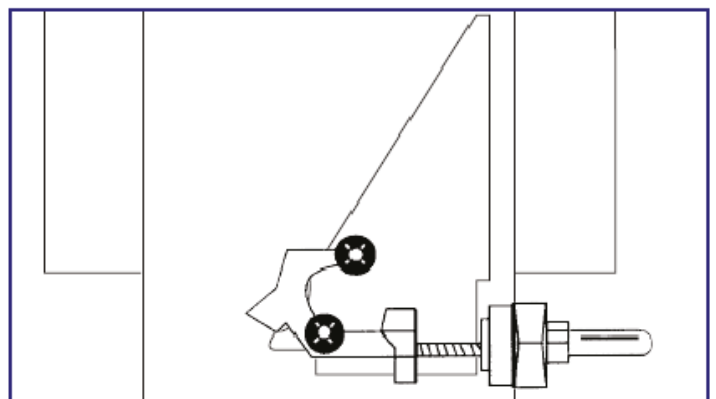

Single Pole Microswitch

To provide remote indication of the blade status. As the leading blade travels to the locking ramp, it contacts the arm and operates the switch. Factory Fitted.

The Single Pole Microswitch is supplied as a dependent snap action contact 1NO + 1NC.

For indication of damper closed, terminals 13 and 14 should be used. Degree of protection: IP66.

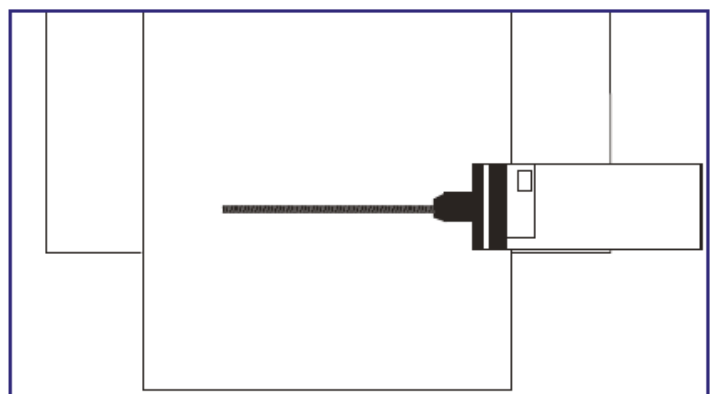
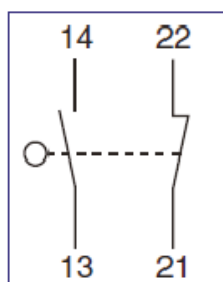

Fusible Link Bracket

The Fusible Link Bracket is manufactured from galvanised steel as standard.

Fusible Link

Blades are held in the open position by a straight bar link (fitted as standard) rated at 72°C (162°F) with a formed reinforcing swage and two location holes.

- BSB can supply the FD Series Fire Damper with the alternative rated fusible link for higher temperature applications as follows:

95°C (202°F)

124°C (260°F)

145°C (286°F)

182°C (360°F)

Blades

Formed to provide a continuous interlocking hinge extending the full length with dual swages providing maximum strength and rigidity. Nominally 0.7mm (22swg) thick cold reduced hot dipped galvanised mild steel to BSEN 10346 Grade DX51D + Z275.

Blade material options to order are Ferritic 430 type 1.4016 grade or Austenitic 316 type 1.4401 grade to BS EN 10088-2.

Microswitches

All BSB FD Fire Dampers are available with factory fitted single or double pole microswitches as optional extras. (See page 9)

Mechanical Visual Indicator

Local visual indication of the blade status is available as an optional extra. (See page 9)

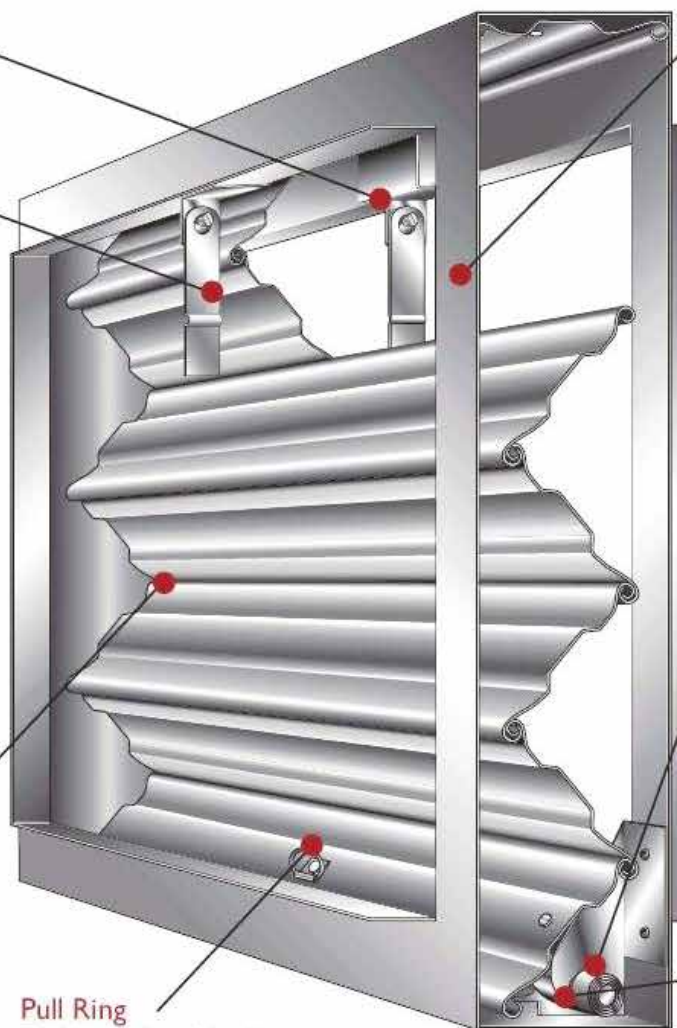

Pull Ring

To aid resetting of the damper blade pack, the bottom closing blade will be fitted with a single pull ring centrally to the width for dampers up to and including 500mm wide or 500mm diameter. For all dimensions above this, two equally spaced pull rings will be fitted.

Gate Latch Release

Optional mechanism for electrical release when required. Rated 72°C (162°F), alternative ratings available as per standard straight bar link.

Casing

Formed to provide two continuous internal flanges not less than 30mm. Casing and components not less than 1.2mm thick cold reduced hot dipped galvanised mild steel to BS EN 10346 Grade DX51D + Z275.

Casing material options to order are Ferritic 430 type 1.4016 grade or Austenitic 316 type 1.4401 grade to BS EN 10088-2.

Side Seals

0.20mm gauge 301 stainless steel to BS EN 10088-2, available to order.

Closure Springs

Dampers are supplied with two constant force coil springs exerting a pull of not less than 35N, with one end fixed to the leading blade by rivets and the coil fitted on the spindle of the locking ramp. The spring is manufactured from Grade 302 stainless steel to BS 5770, 4 hard.

Locking Ramps

Dual locking ramps ensure positive closing action of the blade pack in horizontal or vertical installations.

Paint

All welds, seams and joints are sprayed with commercial grade aluminium paint.



PERFORMANCE DATA

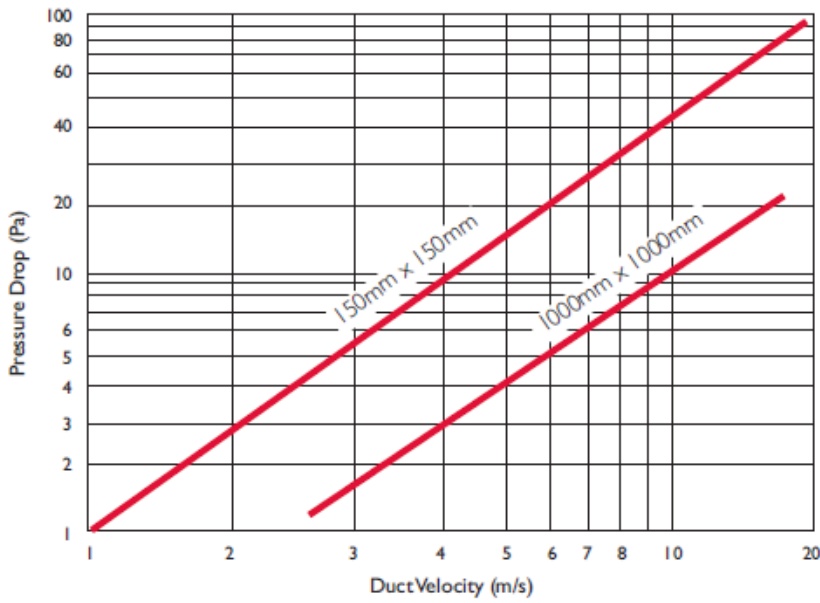

Pressure Drop Graph

Type A and Type I

Minimum free area = 91%

Velocity range 0 to 12.5 m/s

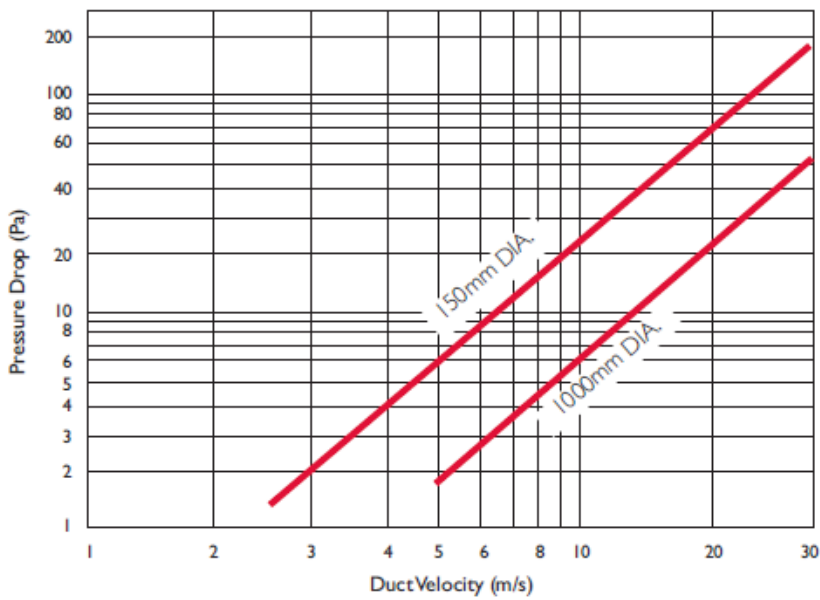

Pressure Drop Graph

Type B, Type C and Type O

Maximum unrestricted airflow

Velocity range 0 to 30 m/s

BASE DIMENSIONS FOR FIRE DAMPERS

Engineered Air Treatment Ltd are experience in designing the most economic layout for minimum modules and the best design to suit a number of installations. The based dimension

Type A
 Square/ Rectangle Spigot Connection
 Blades Partially in Airstream
 on heights greater than 300mm

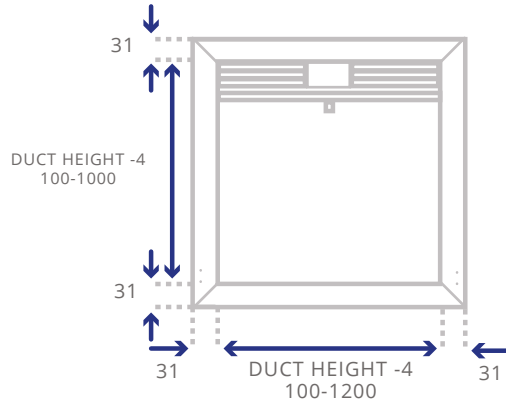
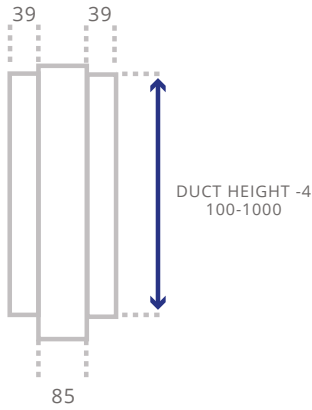

Type B
 Square/ Rectangle Spigot Connection
 Blades Out in Airstream

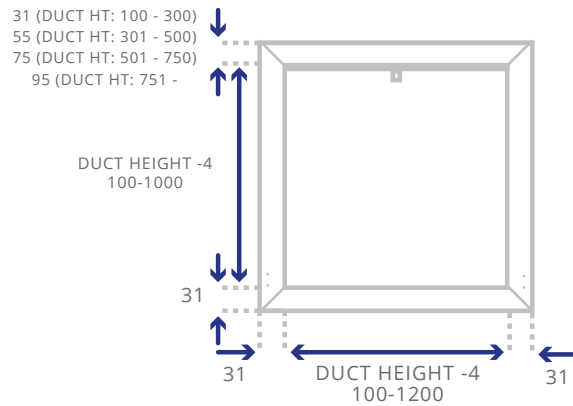
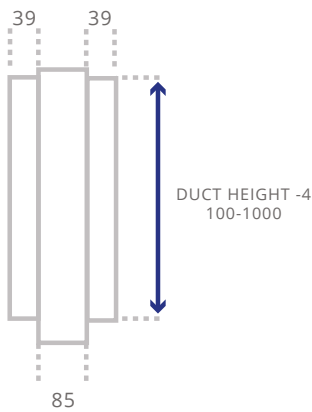

Type C
 Circular Spigot Connection
 Blades Out in Airstream

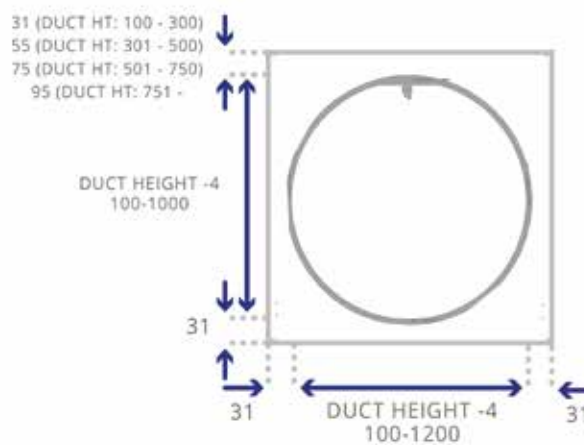
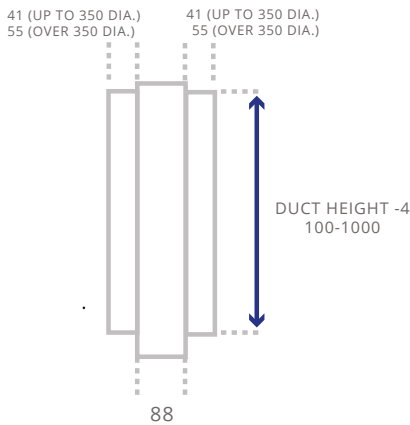

OTHER FIXING METHODS

Angle Frame (AF)

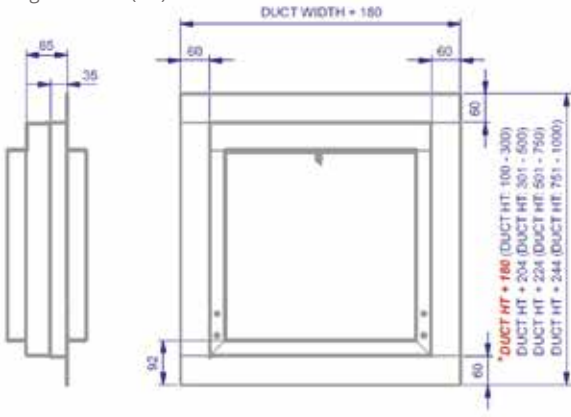

Cleats for Drop Rods (CL)

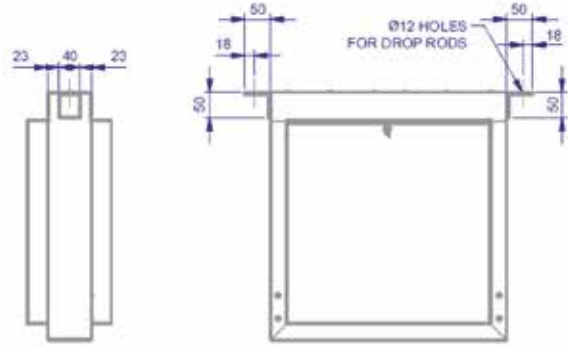

HEVAC Frame (HF)

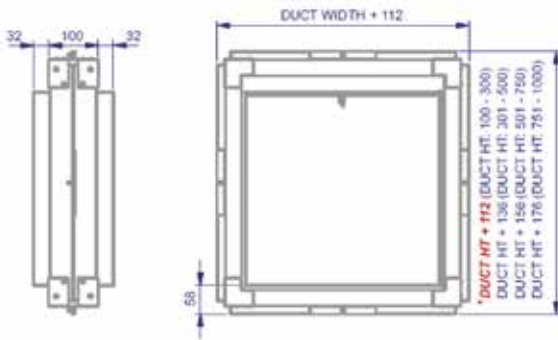

SLOTTED FLANGE DETAIL - BASE DIMENSIONS

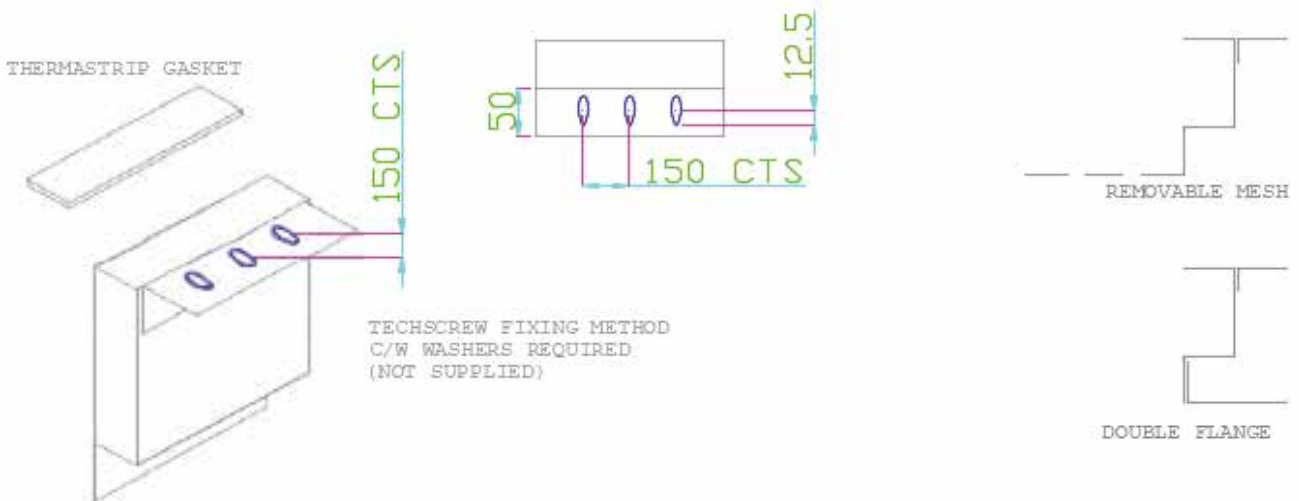

Engineered Air Treatment are proud of our quality record which allows us to have complete confidence in the products we offer. We adhere to our ISO9001 accreditation and install these values into our valuable employees. This confidence allows us to offer a 2 year warranty with all our products.

We also have complete traceability and files over 20 years old to look back on. We are a can do company.

MULTIPLE ARRANGEMENTS

FOR EXAMPLE;
A 4000MM WIDE X 4000MM HIGH OPENING WOULD CONSIST OF
4 INDIVIDUAL APERTURES WITH 2 X 2 FIRE DAMPERS IN EACH MODULE

IN THIS CASE THE CUSTOMER WILL HAVE TO USE 6MM CHANNELS TO SUPPORT THE UNITS-
IN THIS CASE WE HAVE SUGGEST 100MM X 50MM CHANNEL IN THE HORIZONTAL AND VERTICAL.

THESE SUPPORTS NOT INCLUDED IN PRICES AND ARE NOT IN OUR SCOPE OF SUPPLY.

